

ASC100

The flexible solution

La soluzione flessibile

La solución flexible

AVAILABLE MODELS	ASC100-06-V1	ASC100-08-V1	ASC100-Cu
Features Caratteristiche Características	• Self adjustable in 4 conf.		<ul style="list-style-type: none"> • Self adjustable in 2 conf. • Large pulley • Without wire support
Recommended for wire* Raccomandato per filo* Recomendado para hilo*	Conf. B + C: $\varnothing 0,1 \div 1 \text{ mm}$ ($\varnothing .004 \div .04''$) Conf. A + D: $\varnothing 0,1 \div 0,6 \text{ mm}$ ($\varnothing .004 \div .023''$)		$\varnothing 0,1 \div 2,5 \text{ mm}$ ($\varnothing .004 \div .09''$) Copper and aluminium wire
Capacity Capacità di carico Capacidad de carga	CONFIGURATION A AND B		HORIZONTAL PLATE
	100 Kg (220 lb)		100 Kg (220 lb)
	CONFIGURATION C AND D		VERTICAL PLATE
	100 Kg for spools up to 50 mm wide (220 lb - 1.96'')		50 Kg for spools from 51 up to 200 mm wide (110 lb - from 2 up to 7.87'')
\varnothing Plate \varnothing Piatto \varnothing Plato	$\varnothing 620 \text{ mm flat}$ ($\varnothing 24.4''$)	$\varnothing 800 \text{ mm}$ with / without 15 mm border ($\varnothing 31.5'' - .6''$)	$\varnothing 620 \text{ mm flat}$ ($\varnothing 24.4''$)
Plate orientation Orientamento del piatto Orientación del plato	Horizontal / Vertical		
Inside bundle diameter Diametro interno matassa Diámetro interior madeja	$\varnothing 140 \div 450 \text{ mm}$ ($\varnothing 5.5 \div 17.7''$)	$\varnothing 200 \div 640 \text{ mm}$ ($\varnothing 7.8 \div 25.2''$)	$\varnothing 140 \div 450 \text{ mm}$ ($\varnothing 5.5 \div 17.7''$)
Max speed Velocità max Velocidad máxima	120 rpm		125 rpm

*MicroStudio also has a ASC100 model for flat strips up to 14 mm wide, with a plate diameter of 620 or 800 mm

*MicroStudio ha anche un modello di ASC100 per nastri e piattine fino a 14 mm di larghezza ed un diametro del piatto di 620 o 800 mm

*MicroStudio también tiene un modelo de ASC100 para fleje hasta 14 mm de ancho y un diámetro del plato de 620 o 800 mm



ASC100-06-V1 / ASC100-08-V1

CONFIGURATION A
REDUCED DIMENSIONS

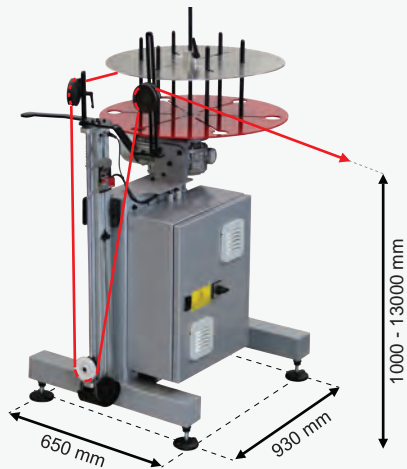

CONFIGURATION B
EVER FOR THICKER WIRE

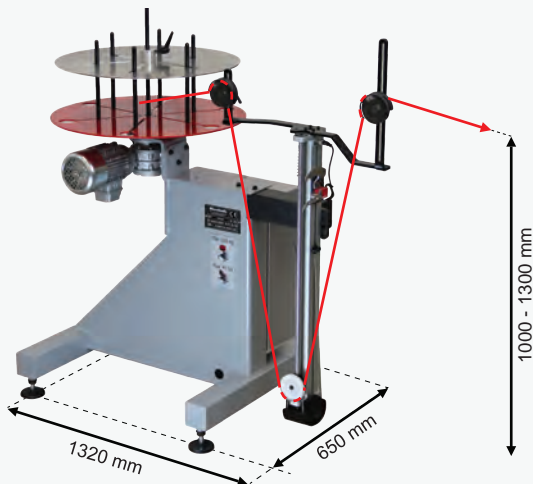

CONFIGURATION C
RECOMMENDED FOR SMALL SPOOLS

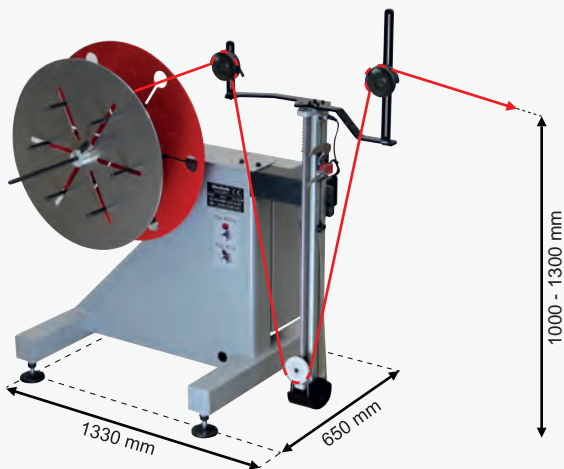

CONFIGURATION D
REDUCED DIMENSIONS

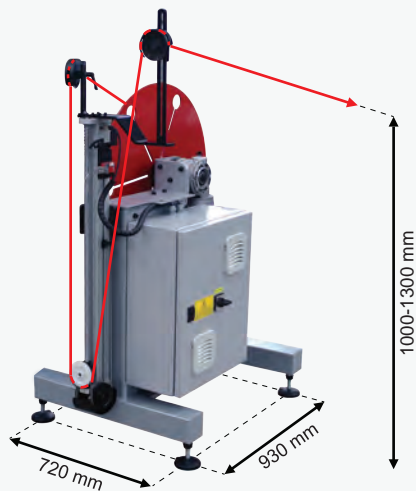

ASC100-Cu

CONFIGURATION A

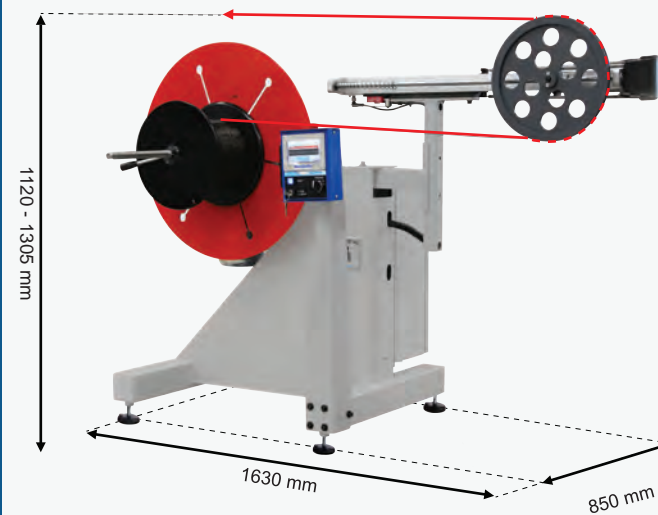

CONFIGURATION B

