

ASC250/600

For 250 and 600 Kg spools and bundles

Für Bündel und Spulen von 250 und 600 Kg

Pour les bobines et les couronnes de 250 et 600 Kg

AVAILABLE MODELS	ASC250-08-V1	ASC250-10-V1	ASC250-08-V3	ASC250-10-V3	ASC600-08-V3	ASC600-10-V3	ASC600-10-V1	ASC600-12-V1
Features Eigenschaften Caractéristiques	<ul style="list-style-type: none"> Reclining side rods to facilitate loading Adjustable tension of the dancer 							
Capacity Tragfähigkeit Portée utile	250 Kg (551 lb)				600 Kg (1322 lb)			
Recommended for wire* Empfohlen für Draht* Recommandé pour fil*	$\varnothing 0,5 \div 3 \text{ mm}$ with ASC-OP-02* $\varnothing 0,1 \div 3 \text{ mm}$ $(\varnothing .01 \div .11" - \varnothing .004 \div .11")$							
\varnothing Plate \varnothing Platte \varnothing Plateau	$\varnothing 800 \text{ mm}$ (31.5")	$\varnothing 1000 \text{ mm}$ (39.3")	$\varnothing 800 \text{ mm}$ (31.5")	$\varnothing 1000 \text{ mm}$ (39.3")	$\varnothing 800 \text{ mm}$ (31.5")	$\varnothing 1000 \text{ mm}$ (39.3")	$\varnothing 1000 \text{ mm}$ (39.3")	$\varnothing 1200 \text{ mm}$ (47.2")
Inside bundle diameter Bund Innendurchmesser \varnothing intérieur de la couronne	$\varnothing 215 \div 600 \text{ mm}$ ($\varnothing 8.46 \div 23.6"$)	$\varnothing 215 \div 700 \text{ mm}$ ($\varnothing 8.46 \div 27.5"$)	$\varnothing 215 \div 600 \text{ mm}$ ($\varnothing 8.46 \div 23.6"$)	$\varnothing 215 \div 700 \text{ mm}$ ($\varnothing 8.46 \div 27.5"$)	$\varnothing 215 \div 600 \text{ mm}$ ($\varnothing 8.46 \div 23.6"$)	$\varnothing 215 \div 700 \text{ mm}$ ($\varnothing 8.46 \div 27.5"$)	$\varnothing 215 \div 700 \text{ mm}$ ($\varnothing 8.46 \div 27.5"$)	$\varnothing 215 \div 900 \text{ mm}$ ($\varnothing 8.46 \div 35.43"$)
Max Speed Höchstgeschwindigkeit Vitesse maximale	85 rpm							

*MicroStudio also has a ASC250 model for flat strips up to 70 mm wide, with a plate diameter of 1000 or 1200 mm

*Microstudio hat auch ein ASC250 Modell für Flachdraht und Bandmaterial bis zu 70 mm Länge und ein Durchmesser der Platte von 1000 mm oder 1200 mm

*MicroStudio dispose d'un modèle de ASC250 pour les feuillard jusqu'à 70 mm de large, avec un diamètre de le plateau de 1000 ou 1200 mm



ASC250-08-V3 / ASC600-08-V3



ASC250-10-V3 / ASC600-10-V3



ASC250-10-V1 / ASC600-10-V1

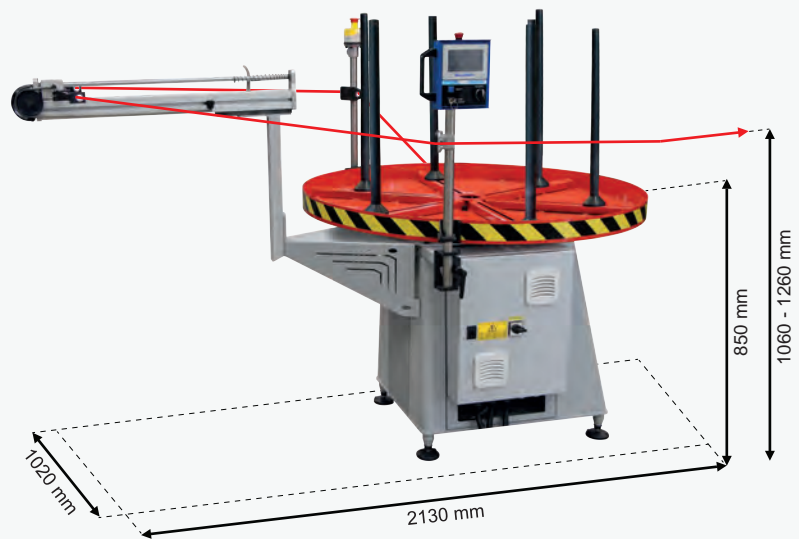

ASC600-12-V1

