

ASC250/600

For 250 e 600 Kg spools and bundles

Per bobine e rocchetti da 250 e 600 Kg

Para bobinas y madejas de 250 y 600 Kg

AVAILABLE MODELS	ASC250-08-V1	ASC250-10-V1	ASC250-08-V3	ASC250-10-V3	ASC600-08-V3	ASC600-10-V3	ASC600-10-V1	ASC600-12-V1
Features Caratteristiche Características	<ul style="list-style-type: none"> Reclining side rods to facilitate loading Adjustable tension of the dancer 							
Capacity Capacità di carico Capacidad de carga	250 Kg (551 lb)				600 Kg (1322 lb)			
Recommended for wire* Raccomandato per filo* Recomendado para hilo*	$\varnothing 0,5 \div 3 \text{ mm}$ with ASC-OP-02* $\varnothing 0,1 \div 3 \text{ mm}$ $(\varnothing .01 \div .11" - \varnothing .004 \div .11")$							
\varnothing Plate \varnothing Piatto \varnothing Plato	$\varnothing 800 \text{ mm}$ (31.5")	$\varnothing 1000 \text{ mm}$ (39.3")	$\varnothing 800 \text{ mm}$ (31.5")	$\varnothing 1000 \text{ mm}$ (39.3")	$\varnothing 800 \text{ mm}$ (31.5")	$\varnothing 1000 \text{ mm}$ (39.3")	$\varnothing 1000 \text{ mm}$ (39.3")	$\varnothing 1200 \text{ mm}$ (47.2")
Inside bundle diameter Diametro interno matassa Diámetro interior madeja	$\varnothing 215 \div 600 \text{ mm}$ ($\varnothing 8.46 \div 23.6"$)	$\varnothing 215 \div 700 \text{ mm}$ ($\varnothing 8.46 \div 27.5"$)	$\varnothing 215 \div 600 \text{ mm}$ ($\varnothing 8.46 \div 23.6"$)	$\varnothing 215 \div 700 \text{ mm}$ ($\varnothing 8.46 \div 27.5"$)	$\varnothing 215 \div 600 \text{ mm}$ ($\varnothing 8.46 \div 23.6"$)	$\varnothing 215 \div 700 \text{ mm}$ ($\varnothing 8.46 \div 27.5"$)	$\varnothing 215 \div 700 \text{ mm}$ ($\varnothing 8.46 \div 27.5"$)	$\varnothing 215 \div 900 \text{ mm}$ ($\varnothing 8.46 \div 35.43"$)
Max speed Velocità max Velocidad máxima	85 rpm							

*MicroStudio also has a ASC250 model for flat strips up to 70 mm wide, with a plate diameter of 1000 or 1200 mm

*MicroStudio ha anche un modello di ASC250 per nastri e piattine fino a 70 mm di larghezza ed un diametro del piatto di 1000 o 1200 mm

*MicroStudio también tiene un modelo de ASC250 para fleje hasta 70 mm de ancho y un diámetro del plato de 1000 o 1200 mm



ASC250-08-V3 / ASC600-08-V3



ASC250-10-V3 / ASC600-10-V3



ASC250-10-V1 / ASC600-10-V1

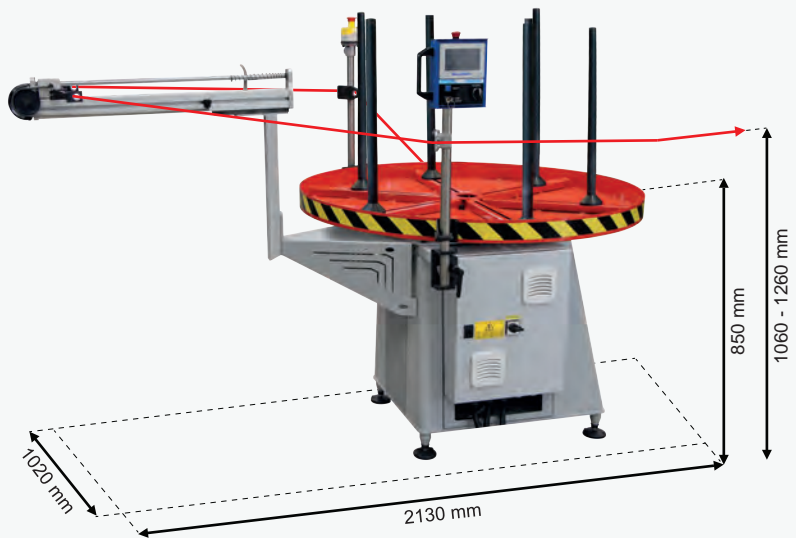

ASC600-12-V1

