

ASC FOR STRIPS

The easy solution to unwind the strips

La soluzione pratica per lo svolgimento delle piattine

La solución práctica para desenrollar las fleje

AVAILABLE MODELS	ASC100-06-V4	ASC100-08-V4	ASC250-10-V4	ASC250-12-V4	ASC600-10-V4	ASC600-12-V4
Features Caratteristiche Características	• Adjustable height of the wire exit		• Reclining side rods to facilitate loading • Adjustable tension of the dancer		• Reclining side rods to facilitate loading • Adjustable tension of the dancer	
Capacity Capacità di carico Capacidad de carga	100 Kg for spools up to 50 mm		250 Kg		600 Kg	
Max strips width Larghezza massima piattina Ancho máximo fleje	Up to 14 mm		Up to 70 mm		Up to 70 mm	
Inside diameter Diámetro interno Diámetro interior	ø 140 ÷ 450 mm	ø 200 ÷ 640 mm	ø 200 ÷ 640 mm		ø 200 ÷ 640 mm	
ø Plate ø Piatto ø Plato	ø 620 mm	ø 800 mm	ø 1000 mm	ø 1200 mm	ø 1000 mm	ø 1200 mm
Max speed Velocità max Velocidad máxima	90 rpm		85 rpm		85 rpm	

ASC100-xx-V4

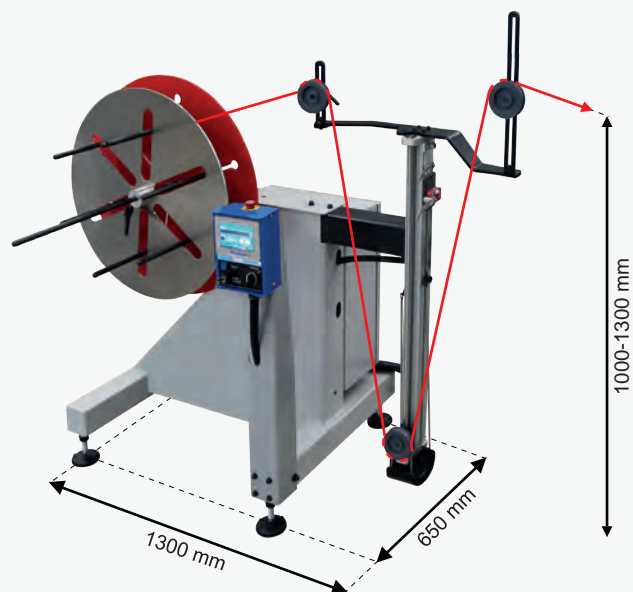

ASC250-xx-V4 / ASC600-xx-V4

